

Robert Matyáš · Jiří Pachman

Primary Explosives

 Springer

Primary Explosives

Robert Matyáš • Jiří Pachman

Primary Explosives

 Springer

Robert Matyáš
Faculty of Chemical Technology
University of Pardubice
Pardubice
Czech Republic

Jiří Pachman
Faculty of Chemical Technology
University of Pardubice
Pardubice
Czech Republic

ISBN 978-3-642-28435-9 ISBN 978-3-642-28436-6 (eBook)
DOI 10.1007/978-3-642-28436-6
Springer Heidelberg New York Dordrecht London

Library of Congress Control Number: 2012945904

© Springer-Verlag Berlin Heidelberg 2013

This work is subject to copyright. All rights are reserved by the Publisher, whether the whole or part of the material is concerned, specifically the rights of translation, reprinting, reuse of illustrations, recitation, broadcasting, reproduction on microfilms or in any other physical way, and transmission or information storage and retrieval, electronic adaptation, computer software, or by similar or dissimilar methodology now known or hereafter developed. Exempted from this legal reservation are brief excerpts in connection with reviews or scholarly analysis or material supplied specifically for the purpose of being entered and executed on a computer system, for exclusive use by the purchaser of the work. Duplication of this publication or parts thereof is permitted only under the provisions of the Copyright Law of the Publisher's location, in its current version, and permission for use must always be obtained from Springer. Permissions for use may be obtained through RightsLink at the Copyright Clearance Center. Violations are liable to prosecution under the respective Copyright Law.

The use of general descriptive names, registered names, trademarks, service marks, etc. in this publication does not imply, even in the absence of a specific statement, that such names are exempt from the relevant protective laws and regulations and therefore free for general use.

While the advice and information in this book are believed to be true and accurate at the date of publication, neither the authors nor the editors nor the publisher can accept any legal responsibility for any errors or omissions that may be made. The publisher makes no warranty, express or implied, with respect to the material contained herein.

Printed on acid-free paper

Springer is part of Springer Science+Business Media (www.springer.com)

Preface

Primary explosives, or initiators, represent a small subset of those chemical compounds called explosives and are used for the purpose of initiating explosions. Simply said, they can be found in various initiation devices where it is necessary to use a mechanical, thermal, or electrical stimulus to prime the combustion or detonation of the main explosive.

We are currently confronted with an overwhelming volume of negative news about the use and abuse of explosives for criminal activities or terrorist bomb attacks, such that the word *explosive* itself has acquired a rather pejorative connotation and is often replaced with the more neutral, but rather meaningless, term *energetic material*. Leaving aside the Orwellian Newspeak, it is fair to say—without any exaggeration—that, although not generally known, explosives are part and parcel of everyday life, much more so now than in the past. If one just considers a small group of explosives used for initiation—primary explosives—we find that most of us are in contact with them on a daily basis, in the form of initiators or pyrotechnic devices in air bag systems, for example. Given this, it seems rather surprising that there has been nothing published in English summarizing the vast knowledge of their properties, preparation, or usage.

Of course, claiming that no information is available on primary explosives would not be entirely true. However, it is common for primary explosives to be discussed in a chapter or a paragraph in publications dealing with explosives in general or in a wider picture (e.g., in T. Urbański's "Chemistry and Technology of Explosives" or David's "The Chemistry of Powder and Explosives"). Another significant source of information are the hundreds or thousands of specialized articles in technical periodicals and papers published in conference publications, which are far too focused on a particular substance or phenomenon and do not allow an easy grasp of the function of primary explosives in the wider context. A fair amount of information is also included in encyclopedias on explosives (of which the most famous and comprehensive are Fedoroff, Sheffield and Kaye's "Encyclopaedia of Explosives and Related Items" or Meyer's "Explosives"). However, information included in these publications is usually rather brief and generally omits many essential details. Very comprehensive and valuable sources of

information on primary explosives are the many publications written in non-English languages, which, despite today's translation capabilities, often remain inaccessible for the majority of potential readers due to the language barrier. This is really regrettable as there are numerous comprehensive and high-quality sources produced in Russian or the Czech language. Here, one should note Bagal's 500-page publication "Khimiya i tekhnologiya initsiiiruyushchikh vzryvshchatykh veshchestv" (Chemistry and Technology of Primary Explosives) written in Russian or Hanus's Czech publication "Méně známé třaskaviny" (Lesser Known Primary Explosives).

Given all the above, the authors of this publication decided to summarize the information on primary explosives included in the sources mentioned above. The information given is not restricted to the traditional primary explosives used in numerous applications, but there is also information on the latest trends and substances which are currently the subject of research and development projects, which are regarded as being potentially useful in the future. The publication also contains some information on primary explosives which are frequently produced illegally by nonprofessionals. Their inclusion represents the authors' intention to provide accurate information on this group of substances, for which the general public, and even the experts, find rather fanciful, distorted, and false information in the mass media and on the Internet. Being chemical engineers, we could not resist the temptation to include also a few substances which are unlikely to be used practically in the future but whose properties are so interesting that omitting them would be unforgivable.

The publication has been written for the general public interested in the field of explosive chemical compounds, but especially for chemistry students and teachers, researchers working in the field of explosives, police officers, criminologists, forensic analysts, soldiers, engineers working in the production of initiators, rock blasters, and others who are likely to come across primary explosives in their various forms in their professional lives. A basic knowledge of chemistry at a secondary school level may be of great benefit to the reader; however, even a complete layman may learn a lot about the properties, methods of preparation, or use of individual substances. Ideally, the publication should assist in achieving a deeper understanding of the role of primary explosives, helping to demystify their extreme sensitivity and dangerousness, and providing precise definitions, enhancing understanding of the historical context of their development and outlining the potential future use of this group of substances.

With the exception of the first two chapters dealing with general performance and sensitivity properties of primary explosives, the structure of the publication is rather simple, each chapter covering a group of substances. The chapters which follow are consistently subdivided and include information on the discovery of the substance, sometimes including a few anecdotal or historical pieces of information, followed by a summary of physical, chemical, and explosive properties, a brief description of methods of preparation and a final part giving information on its usage. We have not sought to discuss special properties in great detail. We aimed to summarize what we consider to be most important and we paid special attention to

thorough referencing to enable the reader easily to find detailed information in the available literature sources. Detailed instructions are not provided for individual syntheses; methods resulting in individual substances are highlighted. In places, where necessary, the topic has been discussed in more detail; in others, it has been simplified. However, it is always rather easy to find the original source, including all details, using the references. To make the rather technical text more user-friendly, we decided to accompany it with photographs of a number of the substances discussed. In most cases, these are the authors' unpublished photographs of products made or supplied by the authors and which cannot therefore be found in the available literature.

In conclusion, let us express our gratitude and thanks to all who supported the development of this project. Without their help, its creation would not have been possible. We would like to thank especially Prof. How-Ghee Ang, director of the Energetics Research Institute, Nanyang Technological University in Singapore, who had the original idea to create such a work and who generously supported the writing of the book throughout the first year of its preparation. We would also like to thank Prof. Svatopluk Zeman, director of the Institute of Energetic Materials, University of Pardubice, Czech Republic for his support in the second stage of its development, especially for creating an inspiring environment for completing the publication. Further, thanks to Mr. Jiří Strnad, in memoriam, for providing valuable and unpublished information, which significantly enhanced the chapter on Explosive Properties of Primary Explosives.

We would also like to express our thanks to Jiří Nesveda and Pavel Valenta for providing expert consultation and for supplying samples of a number of primary explosives, to Lenka Murcková for her ability to obtain even the unobtainable, to Monika Šubrťová for her infinite patience when producing graphs, and to Jakub Šelešovský, Zdeněk Jalový and John Svoboda for the first review of this publication. We would especially like to thank Prof. Stanisław Cudziło from Wojskowa Akademia Techniczna in Warszawa for reviewing the manuscript.

This work was created as part of two projects: project of the Ministry of Education, Youth and Sports of the Czech Republic No. MSM-0021627501 and project of the Ministry of Interior of the Czech Republic No. VG 20102014032.

Contents

1	Introduction to Initiating Substances	1
1.1	Primary Explosives	4
1.2	Priming Compositions	5
1.3	Environmental Hazards: Emergence of Green Initiating Substances	6
	References	10
2	Explosive Properties of Primary Explosives	11
2.1	Influence of Density on Detonation Parameters	11
2.2	Initiating Efficiency	13
2.2.1	Influence of Density and Compacting Pressure	13
2.2.2	Influence of Specific Surface	19
2.2.3	Influence of the Charge Diameter	20
2.2.4	Influence of Confinement	20
2.2.5	Influence of Secondary Charge Type	22
2.2.6	Mixtures	23
2.3	Sensitivity	23
2.3.1	Impact Sensitivity	25
2.3.2	Friction Sensitivity	29
2.3.3	Sensitivity to Electrostatic Discharge	31
2.3.4	Sensitivity to Flame	32
	References	33
3	Fulminates	37
3.1	Introduction	37
3.1.1	Fulminic Acid	37
3.1.2	Mercury Fulminate	39
3.1.3	Silver Fulminate	58
3.1.4	Other Fulminates	62
	References	66

4	Azides	71
4.1	Azoimide	71
4.2	Lead Azide	72
4.2.1	Physical and Chemical Properties	72
4.2.2	Chemical Reactivity	74
4.2.3	Sensitivity	77
4.2.4	Explosive Properties	78
4.2.5	Preparation	80
4.2.6	Spontaneous Explosions During Crystal Growth	85
4.2.7	Uses	86
4.3	Other Substances Derived from Lead Azide	87
4.3.1	Basic Lead Azide	87
4.3.2	Lead (IV) Azide	88
4.4	Silver Azide	89
4.4.1	Physical and Chemical Properties	89
4.4.2	Sensitivity	91
4.4.3	Explosive Properties	92
4.4.4	Preparation	93
4.4.5	Uses	96
4.5	Copper Azides	96
4.5.1	Physical and Chemical Properties	97
4.5.2	Explosive Properties	98
4.5.3	Preparation	100
4.5.4	Undesired Formation of Copper Azides	102
4.5.5	Uses	104
4.6	Other Metallic Azides	105
4.6.1	Physical and Chemical Properties	105
4.6.2	Explosive Properties	106
4.6.3	Preparation	108
4.6.4	Uses	110
4.7	Organic Azides	110
4.8	Cyanuric Triazide	111
4.8.1	Physical and Chemical Properties	112
4.8.2	Explosive Properties	112
4.8.3	Preparation	115
4.8.4	Uses	115
4.9	4,4',6,6'-Tetra(azido)hydrazo-1,3,5-triazine and 4,4',6,6'-Tetra (azido)azo-1,3,5-triazine	116
4.9.1	Physical and Chemical Properties	116
4.9.2	Explosive Properties	116
4.9.3	Preparation	117
4.9.4	Uses	118
4.10	1,3,5-Triazido-2,4,6-trinitrobenzene	118
4.10.1	Physical and Chemical Properties	118
4.10.2	Explosive Properties	119

4.10.3	Preparation	120
4.10.4	Uses	121
4.11	2,3,5,6-Tetraazido-1,4-benzoquinone	121
4.11.1	Physical Properties	121
4.11.2	Explosive Properties	122
4.11.3	Preparation	123
4.11.4	Uses	123
	References	123
5	Salts of Polynitrophenols	131
5.1	Salts of Picric Acid	131
5.1.1	Normal Lead Picrate	132
5.1.2	Basic Lead Picrate	133
5.2	Salts of Dinitroresorcinol	133
5.2.1	Lead salts of 2,4-Dinitroresorcinol	133
5.2.2	Lead Salts of 4,6-Dinitroresorcinol	135
5.3	Salts of Trinitroresorcine	138
5.3.1	Lead Styphnate	138
5.3.2	Basic Lead Styphnate	145
5.3.3	Double Salts of Lead Styphnate	148
5.3.4	Barium Styphnate	149
5.3.5	Other Salts of Styphnic Acid	152
	References	152
6	Diazodinitrophenol	157
6.1	Introduction	157
6.2	Structure	157
6.3	Physical and Chemical Properties	159
6.4	Explosive Properties	160
6.5	Preparation	162
6.6	Use	164
	References	165
7	Salts of Benzofuroxan	167
7.1	Introduction	167
7.2	Salts of 4,6-Dinitrobenzofuroxan	168
7.2.1	Physical and Chemical Properties	169
7.2.2	Explosive Properties	169
7.2.3	Preparation of 4,6-Dinitrobenzofuroxan	172
7.2.4	Preparation of 4,6-Dinitrobenzofuroxan Salts	173
7.2.5	Uses	174
7.3	Potassium Salt of 7-Hydroxylamino-4,6-dinitro-4,7-dihydrobenzofuroxan	175
7.4	Potassium Salt of 7-Hydroxy-4,6-dinitrobenzofuroxan	176
7.4.1	Physical and Chemical Properties	176
7.4.2	Explosive Properties	176

7.4.3	Preparation	177
7.4.4	Uses	179
7.5	Salts of Bis(furoxano)-2-nitrophenol	179
7.5.1	Physical and Chemical Properties	180
7.5.2	Explosive Properties	180
7.5.3	Preparation	181
7.5.4	Uses	182
	References	183
8	Tetrazoles	187
8.1	Tetrazene	189
8.1.1	Physical and Chemical Properties	190
8.1.2	Explosive Properties	191
8.1.3	Preparation	192
8.1.4	Uses	193
8.2	5-Aminotetrazole Salts	194
8.2.1	Physical and Chemical Properties	194
8.2.2	Explosive Properties	195
8.2.3	Preparation	195
8.2.4	Uses	197
8.3	5-Nitrotetrazole Salts	197
8.3.1	Physical and Chemical Properties	197
8.3.2	Explosive Properties	199
8.3.3	Preparation	203
8.3.4	Uses	206
8.4	5-Chlorotetrazole Salts	207
8.4.1	Physical and Chemical Properties	207
8.4.2	Explosive Properties	207
8.4.3	Preparation	208
8.4.4	Uses	209
8.5	5-Azidotetrazole Salts	209
8.5.1	Physical and Chemical Properties	209
8.5.2	Explosive Properties	209
8.5.3	Preparation	210
8.5.4	Uses	211
8.6	5,5'-Azotetrazole Salts	212
8.6.1	Physical and Chemical Properties	213
8.6.2	Explosive Properties	214
8.6.3	Preparation	216
8.6.4	Uses	217
8.7	Tetrazoles with Organic Substituent	217
8.7.1	5-Picrylamino-tetrazole	218
8.7.2	1-(1 <i>H</i> -Tetrazol-5-yl)guanidinium Nitrate	219

8.8	Organic Derivatives of 5-Nitrotetrazole	221
8.9	Organic Derivatives of 5-Azidotetrazole	222
8.9.1	Explosive Properties	222
8.9.2	Preparation	222
	References	223
9	Tetrazole Ring-Containing Complexes	227
9.1	Cobalt Perchlorate Complexes	228
9.1.1	Pentaamine(5-cyano-2 <i>H</i> -tetrazolato- <i>N</i> ²)cobalt(III) perchlorate (CP)	228
9.1.2	CP Analogs	235
9.1.3	1,5-Cyclopentamethylenetetrazole Complexes	238
9.1.4	Tetraammine- <i>cis</i> -bis(5-Nitro-2 <i>H</i> -tetrazolato- <i>N</i> ²) cobalt(III) perchlorate (BNCP)	241
9.1.5	BNCP Analogs	244
9.1.6	Perchlorate Complexes of 1,5-Diaminotetrazole	245
9.1.7	Other Perchlorate-Based Complexes	247
9.2	Perchlorate-Free Complexes	247
9.2.1	Iron- and Copper-Based 5-Nitrotetrazolato- <i>N</i> ² Complexes	247
9.2.2	Perchlorate-Free CP Analogs	250
9.3	Other Transition Metal-Based 5-Nitrotetrazolato- <i>N</i> ² Complexes	251
	References	252
10	Organic Peroxides	255
10.1	Peroxides of Acetone	255
10.1.1	Diacetone Diperoxide	256
10.1.2	Triacetone Triperoxide	262
10.1.3	Tetraacetone Tetraperoxide	274
10.2	Hexamethylene Triperoxide Diamine	275
10.2.1	Physical and Chemical Properties	275
10.2.2	Explosive Properties	278
10.2.3	Preparation	279
10.2.4	Uses	280
10.3	Tetramethylene Diperoxide Dicarbamide	280
10.3.1	Physical and Chemical Properties	281
10.3.2	Preparation	281
10.3.3	Use	281
	References	282

11 Nitrogen Halides	289
11.1 Nitrogen Trichloride	289
11.1.1 Physical and Chemical Properties	289
11.1.2 Explosive Properties	290
11.1.3 Preparation	291
11.1.4 Use	293
11.2 Nitrogen Tribromide	293
11.2.1 Physical and Chemical Properties	294
11.2.2 Preparation	294
11.3 Nitrogen Triiodide	295
11.3.1 Structure	296
11.3.2 Physical and Chemical Properties	297
11.3.3 Explosive Properties	298
11.3.4 Preparation	299
11.3.5 Use	300
References	300
12 Acetylides	303
12.1 Silver Acetylides	303
12.1.1 Silver Acetylide	304
12.1.2 Silver Acetylide–Silver Nitrate	308
12.1.3 Silver Acetylide–Silver Hexanitrate	312
12.1.4 Other Salts of Silver Acetylide–Silver Nitrate	312
12.2 Cuprous Acetylide	313
12.2.1 Physical and Chemical Properties	313
12.2.2 Explosive Properties	314
12.2.3 Preparation	315
12.2.4 Uses	316
12.3 Cupric Acetylide	316
12.3.1 Physical and Chemical Properties	316
12.3.2 Explosive Properties	317
12.3.3 Preparation	317
12.3.4 Uses	318
12.4 Mercuric Acetylide	318
12.4.1 Physical and Chemical Properties	318
12.4.2 Explosive Properties	319
12.4.3 Preparation	319
12.4.4 Uses	320
12.5 Mercurous Acetylide	320

12.6	Aurous Acetylide	321
12.6.1	Physical and Chemical Properties	321
12.6.2	Explosive Properties	321
12.6.3	Preparation	321
	References	322
13	Other Substances	325
13.1	Salts of Nitramines	325
13.2	Organophosphates	328
13.3	Hydrazine Complexes	331
	References	333
	Index	335

List of Abbreviations

2,4-DNR	2,4-Dinitroresorcinol; 2,4-dinitrobenzene-1,3-diol
2,4-LDNR	Lead salt of 2,4-dinitroresorcinol; lead salt of 2,4-dinitrobenzene-1,3-diol
4,6-DNR	4,6-Dinitroresorcinol; 4,6-dinitrobenzene-1,3-diol
4,6-LDNR	Lead salt of 4,6-dinitroresorcinol; lead salt of 4,6-dinitrobenzene-1,3-diol
5-ATZ	5-Amino-1 <i>H</i> -tetrazole
5-PiATZ	5-(2,4,6-Trinitrophenylamino)-1 <i>H</i> -tetrazole
Å	Ångström (10^{-10} m)
APCP	Pentaammin-aqua cobalt(III) perchlorate
ATZ	5-Amino-1 <i>H</i> -tetrazole
AzTZ	5,5'-Azo-1 <i>H</i> -tetrazole
b.p.	Boiling point
BAM	Bundesanstalt für Materialforschung und prüfung
BaS	Barium styphnate; barium salt of 2,4,6-trinitrobenzene-1,3-diol
BFNP	Bis(furoxano)-2-nitrophenol
BNCP	Tetraammine- <i>cis</i> -bis(5-nitro-2 <i>H</i> -tetrazolato- <i>N</i> ²)cobalt(III) perchlorate
CL-14	5,7-Diamino-4,6-dinitrobenzofuroxan
CL-20	2,4,6,8,10,12-Hexanitro-2,4,6,8,10,12-hexaazaisowurtzitan (HNIW)
CMC	Carboxymethyl cellulose
CoHN	Cobalt hydrazine nitrate
CP	Pentaamine(5-cyano-2 <i>H</i> -tetrazolato- <i>N</i> ²)cobalt(III) perchlorate
CPCN	Pentaammine-carbonato cobalt(III) nitrate
CTCN	Tetraamine-carbonato cobalt(III) nitrate
<i>D</i>	Detonation velocity
DADP	Diacetone diperoxide; 3,3,6,6-tetramethyl-1,2,4,5-tetroxane
DAHA	4,4,6,6,8,8-Hexaazido-1,3,5,7,2λ ⁵ ,4λ ⁵ ,6λ ⁵ ,8λ ⁵ -tetrazatetraphosphocine-2,2-diamine
DANT	4,6-Diazo- <i>N</i> -nitro-1,3,5-triazine-2-amine
DDNP	2-Diazo-4,6-dinitrophenol

DDT	Deflagration-to-detonation transition
Dinol	2-Diazo-4,6-dinitrophenol
DNBF	4,6-Dinitrobenzofuroxan
DNR	Dinitroresorcinol; 1,3-dihydroxybenzene
DSC	Differential scanning calorimetry
DTA	Differential thermal analysis
DTG	Differential thermogravimetry
<i>E</i>	Energy
<i>E</i> ₅₀	Energy causing initiation in 50 % of the trials
EDNA	<i>N,N</i> -dinitromethylenediamide
<i>E</i> _{min}	Minimal energy causing initiation
en	1,2-Ethylenediamine; ethane-1,2-diamine
ENTA	7,7,9,9-Tetraazido-1,4-dinitro-1,4,6,8,10-pentaaza-5 λ ⁵ ,7 λ ⁵ ,9 λ ⁵ -triphospha-spiro[4.5]deca-5,7,9-triene
ERDE	Explosives Research and Development Establishment
ESD	Electrostatic discharge
Et ₂ O	Diethylether
F of I	Figure of insensitivity (explosives having a 50 % initiation drop height equal to that of RDX are given a F of I of 80)
FOX-7	2,2-Dinitroethene-1,1-diamine
GNGT	Tetrazene
<i>h</i> ₁₀	Impact height causing initiation in 10 % of the trials with particular hammer mass
<i>h</i> ₅₀	Impact height causing initiation in 50 % of the trials with particular hammer mass
<i>h</i> _{min}	Minimal impact height causing initiation with particular hammer mass
HMTD	Hexamethylene triperoxide diamine; 1,6-diaza-3,4,8,9,12,13-hexaoxabicyclo[4,4,4]tetradecane
HMX	1,3,5,7-Tetranitro-1,3,5,7-tetrazocane (octogen)
HNT	5-Nitro-1 <i>H</i> -tetrazole
IR	Infrared spectroscopy
IUPAC	International Union of Pure and Applied Chemistry
KBFNP	Potassium salt of bis(furoxano)-2-nitrophenol
KDNBF	Potassium salt of 2,4-dinitrobenzofuroxan
KDNP	7-Hydroxy-4,6-dinitrobenzofuroxan
LA	Lead azide
LD ₅₀	Median lethal dose
LDDS	Double lead salts of styphnic acid with 1,3-di(5-tetrazoyl)triazene
LS	Lead styphnate; lead salt of 2,4,6-trinitrobenzene-1,3-diol
<i>m</i> -	Meta
m.p.	Melting point
Me	Metal
MF	Mercury fulminate
MO	Molecular orbital
<i>n</i> _c / <i>n</i> _a	Molar ratio of catalyst to acetone

NC	Nitrocellulose
NG	Nitroglycerine
NHN	Nickel hydrazine nitrate
NKT	Pentaamine (5-nitro-2 <i>H</i> -tetrazolato- <i>N</i> ²)cobalt(III) perchlorate
NMR	Nuclear magnetic resonance
NT	5-Nitro-1 <i>H</i> -tetrazole
<i>o</i> -	Ortho
<i>P</i>	Pressure
<i>p</i> -	Para
PAC	Pentaamine(1,5-cyclopentamethylene-tetrazolato- <i>N</i> ³) cobalt(III) perchlorate
PbNATNR	Double lead salt of styphnic acid and 5-nitraminotetrazole
PBX	Plastic bonded explosives
PDT	Plate dent test
PETN	Pentaerythritol tetranitrate
PiC	Picrylchloride; 1-chloro-2,4,6-trinitrobenzene
pK_a	The negative logarithm of the acid dissociation constant
prob.	Probability
PVA	Polyvinylalcohol
PVP-1	Detonation transition element in oil well perforators
RC	Reinforcing cap
RDX	1,3,5-Trinitro-1,3,5-triazinane (hexogen)
SA	Silver azide
SEM	Scanning electron microscopy
SF	Silver fulminate
SII	Simple initiating impulse
STANAG	NATO abbreviation for Standardization Agreement
<i>T</i>	Temperature
TAAT	4,4',6,6'-Tetra(azido)azo-1,3,5-triazine
TAHT	4,4',6,6'-Tetra(azido)hydrazo-1,3,5-triazine
TATNB	1,3,5-Triazido-2,4,6-trinitrobenzene
TATP	Triacetone triperoxide; 3,3,6,6,9,9-hexamethyl-1,2,4,5,7,8-hexaoxonane
T_{dec}	Decomposition temperature
TeATeP	3,3,6,6,9,9,12,12-Octamethyl-1,2,4,5,7,8,10,11-octaaoxacyclododecane
TeAzQ	2,3,5,6-Tetraazido-1,4-benzoquinone
Tetryl	<i>N</i> -methyl- <i>N</i> ,2,4,6-tetranitroaniline
TMD	Theoretical maximum density
TMDD	Tetramethylene diperoxide dicarbamide; 1,2,8,9-tetraoxa-4,6,11,13-tetraazacyclotetradecane-5,12-dione
TNR	Trinitroresorcinol; 2,4,6-trinitrobenzene-1,3-diol
TNT	2,4,6-Trinitrotoluene
UV	Ultraviolet
ΔH_f	Heat of formation
ρ	Density

Chapter 1

Introduction to Initiating Substances

Initiating substances (primaries) are chemical compounds/mixtures used in igniters or detonators to bring about burning or detonation of energetic material. The vocabulary regarding initiators is rather vast, often divided by the type of input and output of the element or its application. In general, igniters (containing a priming composition) are used to provide flame, while detonators (containing the primary explosive) are designed to create a shock wave which starts the detonation reaction in a secondary explosive. Combinations of both are seen, for example, in detonators in which the igniter is first initiated and the resulting flame starts the detonator [1].

The successful initiation of explosives begins with a small external stimulus called the simple initiating impulse (SII). The SII is a nonexplosive type of impulse such as flame, heat, impact, stab, friction, electric spark, etc. The choice depends on the type of material to be initiated and on the desired output effect. The energy provided by this impulse is sufficient enough to initiate the burning of a priming mixture—a sensitive mixture sometimes called prime (in pyrotechnics the term prime is used for the first layer enabling successful ignition). The energy from the combustion of the priming composition needs to be magnified or delayed by a sequence of elements, such as delay, transfer, and output charges. The entire sequence is called an explosive train and is simplified in Fig. 1.1.

The term primer in Fig. 1.1 represents the first element in the explosive train with flame as a desired output (e.g., percussion primer, pyrotechnic prime, electric fusehead, safety fuse, etc.). It needs to be stressed here that consistency in terminology does not exist regarding the term primer which is often used for primary explosives and boosters, but also for a charge consisting of detonating cord, detonator, and transfer charge made of secondary explosive, for detonator fused booster charges or more commonly for percussion-sensitive pyrotechnic mixtures loaded in small metal caps used in ammunition cartridges. Regarding Fig. 1.1, the primer is, as stated, the first element in the explosive train sensitive to the SII. All such elements contain a priming composition, which is typically a pyrotechnic mixture designed specifically for each particular application from a variety of substances (the topic is briefly described in later parts of this chapter). The transfer

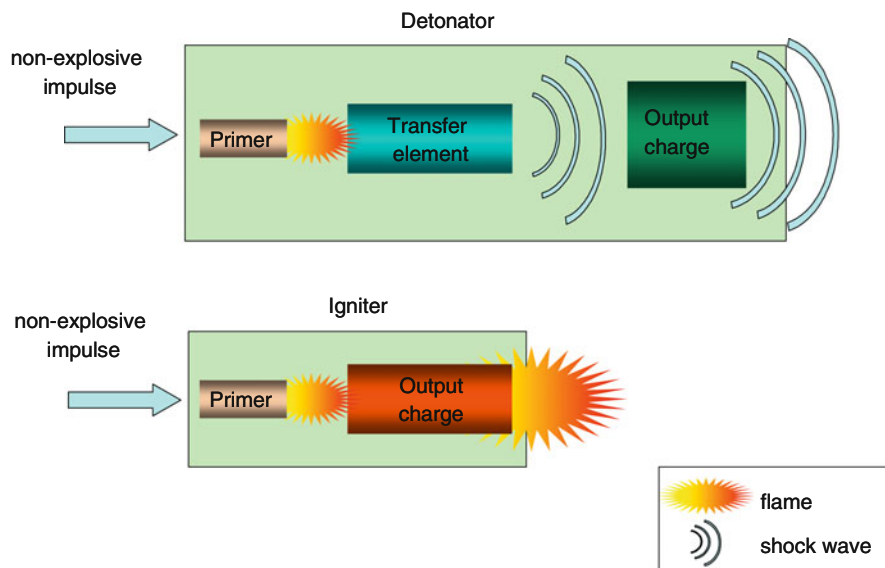

Fig. 1.1 Schematic representation of the two most common types of explosive trains

element in Fig. 1.1 represents any element used in the detonation train to augment or delay the initial impulse. The materials for such an element may range from a primary explosive (column of lead azide or 2-diazo-4,6-dinitrophenol—dinol) or pyrotechnic mixtures (e.g., $\text{FeSiCr/Pb}_3\text{O}_4$) to black powder. The output charges are secondary explosives, pyrotechnic mixtures, or propellants depending on the type of application.

In the following text, we have decided to adopt an approach in which we divide the vast group of sensitive condensed energetic materials according to various criteria (Fig. 1.2). The first criterion we used is their usefulness in real applications. We further divide those that have found a use depending upon the type of the desired function into two groups: (a) detonating substances (primary explosives) and deflagrating substances or mixtures (priming mixtures, primes). The term primary explosive is generally used for individual substances (not mixtures) which are further divided based on their response to flame into those which detonate practically immediately after ignition and those that require some distance/time for developing stable detonation. The former are sometimes referred to as detonants in Anglo-American literature, whereas in Czech literature these are called primary explosives belonging to the group of lead azide, while the latter belong to the group of mercury fulminate. In Russian literature, the latter are denominated as pseudo primary explosives because they must undergo so-called deflagration to detonation transition, which is a process of accelerating the burning reaction zone to a point where the propagation mechanism changes from being heat transfer driven to being shock wave driven.

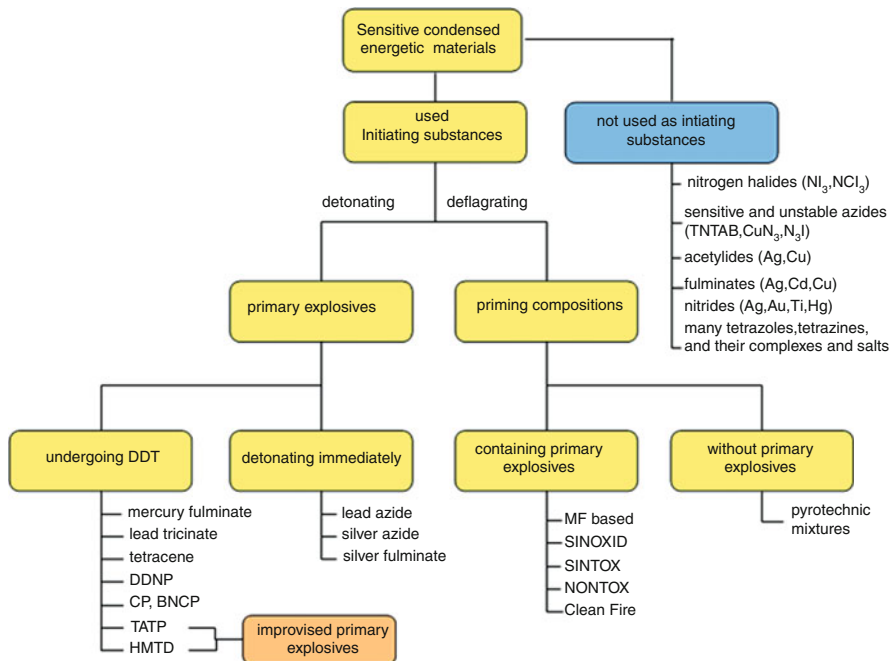

Fig. 1.2 Subdivisions of sensitive energetic materials with some common examples

It is difficult, if not impossible, to draw a clear line between substances used for igniters and those used for detonators. These two groups overlap in many compositions. Mercury fulminate, for example, is a well-known primary explosive used in the past, capable of detonation, but which found a use in priming compositions much earlier than it did in detonators. It should therefore be understood that any type of partitioning of initiating substances is rather artificial and cannot be considered rigorous or definitive. Whether a substance finds a use as a primary explosive in a detonator, as part of a priming mixture or does not find any use at all depends on a large number of criteria which we have tried to introduce in Chap. 2. Many substances are disqualified from practical application due to their inability to meet these stringent criteria. Some examples include substances that are too sensitive for practical application (e.g. fulminating silver, silver acetylide, nitrogen triiodide), substances with low initiating efficiency (e.g. nitrogen triiodide, tetrazene), chemically unstable substances (e.g. 1,6-diaza-3,4,8,9,12,13-hexaoxabicyclo[4,4,4]tetradecane—HMTD), etc. Further, there are substances that are sensitive but are not expected to explode in their typical application (diazonium intermediate products in the dye industry, dibenzoyl and other peroxides used as catalysts of radical reactions, etc.), substances used in the entertainment world for creating sound or light effects, etc.

Further we have included some of those that we believe may attract attention in the future although they are not used at the moment (tetrazole salts and complexes).

The main focus of this monograph is on the individual primary explosives that have been used or reported as promising candidates for potential use. The only exception we included is nitrogen triiodide, which we believe will never find any use. The priming compositions are covered only briefly in this chapter to give more space to discussing the use of primary explosives in a broader perspective.

1.1 Primary Explosives

Primary explosives are sensitive mixtures/compounds that can be easily detonated by an SII—nonexplosive means such as flame, heat, impact, friction, electric spark, etc. They are mainly used in applications where it is desired to produce shock for initiation of a less sensitive explosive (secondary explosive). The ability to initiate detonation of secondary explosives is the characteristic that makes primary explosives useful in detonators and blasting cups or caps (detonators used for mining). In order for this to work, primary explosives must detonate shortly after the nonexplosive initiation. The fast transition from SII to detonation (sometimes referred to as acceleration) is the most important distinction between primary and secondary explosives.

Another important use of primary explosives lies in their application as sensitizers in priming compositions. The purpose of such mixtures is to provide reliable ignition and the role of the primary explosives in such mixtures is to make them sensitive enough to be easily ignited. The detonation of such a mixture is undesirable and must be prevented by careful selection of the ingredients and their quantities for a particular application.

The first substance ever used as a primary explosive was mercury fulminate (MF). It was patented for use in priming mixtures in 1807 and it took another 60 years before Nobel realized that it was possible to use MF in “Fulminate Blasting Caps”—practically the first detonators—for initiation of detonation of nitroglycerine. The price of mercury and the toxicity of decomposition products led to the search for suitable replacements. Even though lead azide (LA) was tested before 1900 as a replacement for MF in detonators, production of MF continued to grow and peaked during World War I. The toxicity of MF, which was even at that time considered a problem in priming mixtures, was not seen as a big issue in the case of detonators. The real replacement of MF in detonators was a lengthy process closely related to improvements in manufacturing of a suitable form of LA.

Apart from the already mentioned lead azide and mercury fulminate, the classic examples of primary explosives include lead styphnate (LS), silver azide (SA), dinol (DDNP), and tetrazene (GNGT). Primary explosives (individual components) are often mixed and used in the form of compositions rather than as single component energetic materials. Mixtures may consist of either individual primary explosives (astryl-MF/SA [2]) or primary explosives plus some nonexplosive additive (LA/LS/dextrine or ASA composition—LA/LS/Al).

Table 1.1 Example of typical historical priming composition [1]

Substance	Amount (wt%)
Mercury fulminate	13.7
Potassium chlorate	41.5
Antimony sulfide	33.4
Powdered glass	10.7
Gelatin glue	0.7

Table 1.2 Example of typical historical priming compositions without potassium chlorates [3]

Substance	Amount (wt%)		
MF	40	50	36
Barium nitrate	40	–	–
Lead chromate	–	24	–
Lead dioxide	–	20	–
Mercury chromate	–	–	40
Antimony sulfide	14	–	20
Glass powder	6	6	4

1.2 Priming Compositions

Priming compositions or priming mixtures are sensitive explosive mixtures that are designed to produce a flame in a particular application. They are most often mixtures containing a primary explosive as one of the components in such a form and amount that ensures the inability to initiate detonation of the mixture. The role of the primary explosive is to sensitize the mixture to external stimuli, not to make it detonatable. Priming mixtures are used in percussion caps for ignition of gun powder, on electric fuseheads, delay elements, etc.

The typical examples of priming mixtures used almost exclusively in the nineteenth century include mercury fulminate, potassium chlorate, antimony sulfide, glass powder, and gum Arabic. The priming mixtures widely used for small arms in the USA in the early 1900s were based on MF. The composition of the most typical one is summarized in Table 1.1.

At the time of black powder, weapons had to be carefully cleaned after use. The combustion products of priming mixtures therefore did not present such a crucial problem since they were in any case removed together with the black powder residues during cleaning. The problem of corrosive products became apparent when black powder was replaced by smokeless powder which meant much less careful cleaning of weapons. Potassium chlorates as a part of the priming composition have therefore been abandoned and replaced by other oxidizers. Some of the compositions from that time can be seen in Table 1.2 [3].

The use of alternative oxidizers led to mixtures that were not corrosive but contained MF, which liberated toxic mercury vapors during firing. To overcome the problem of toxicity, Edmund von Herz proposed replacing MF in priming compositions with lead hypophosphite nitrate (1913) and later by the lead salt of trinitroresorcine (1914). The more important of these two MF substitutes was the

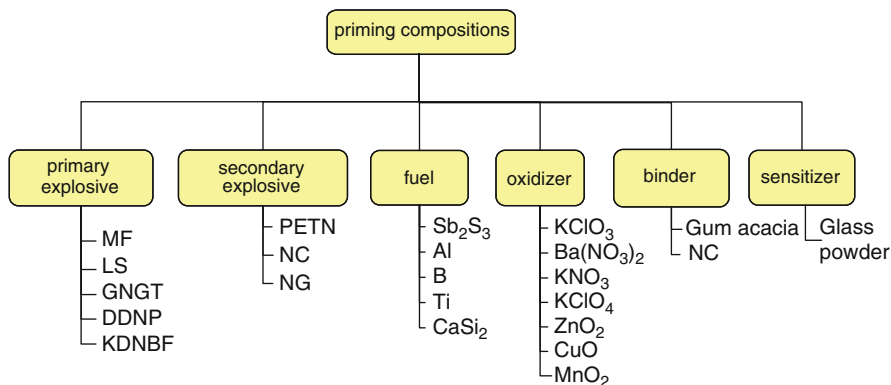

Fig. 1.3 Typical examples of components found in priming compositions

latter—the lead salt of trinitroresorcine; so-called lead styphnate, lead triciniate, or simply just triciniate. This substance, however, does not possess sufficient percussion sensitivity and therefore did not find wider use until the introduction of tetrazene by Rathsburg in 1921 [3]. Some patented compositions contained both MF and triciniate [4].

Typical primary mixtures contain some of the following: lead styphnate, tetrazene, aluminum, antimony sulfide, calcium silicate, lead peroxide, boron, metals, barium nitrate, secondary explosive, binder, sensitizer, etc. (Fig. 1.3). Variations in the ingredients and their relative amounts result in compositions which possess sensitivity and ignition properties tailored to specific requirements.

The replacement of mercury was a significant improvement with respect to the toxicity of the combustion products. It led, however, to the introduction of triciniate which also presents health problems due to its lead content. Concerns over environmental hazards resulted in the search for lead-free or, more generally, heavy metal-free compositions which would eliminate the health threat while maintaining performance and other important properties at least to the level of lead-containing predecessors [5].

1.3 Environmental Hazards: Emergence of Green Initiating Substances

The problem of toxicity, as it is seen today, is caused mainly by lead which is present in primary explosives in form of lead azide and in priming mixtures mostly as lead styphnate. The evolution in the initiating materials is therefore heading toward lead-free, environmentally friendly, “green” initiating substances or more specifically “green primary explosives” and “green priming compositions.”

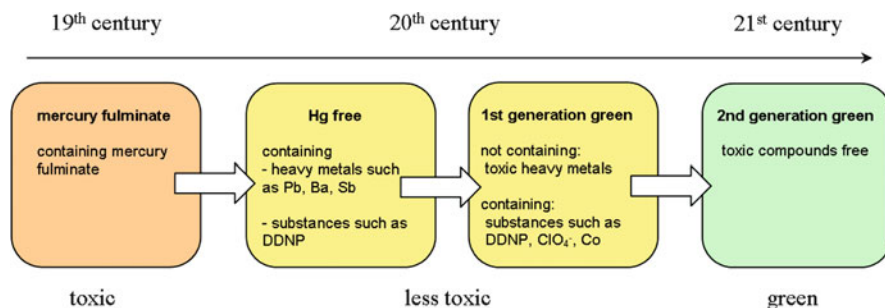

Fig. 1.4 Evolution of primary explosives and priming mixtures from the perspective of toxicity

The term “green” is “science marketing” more than anything else and is quite confusing as it describes compositions not containing lead, as well as compositions without heavy metals such as Hg, Pb, Ba, and Sb or more recently also compositions that do not contain any toxicologically potentially hazardous substances such as DDNP (often found in green compositions today). Further, the term “green initiating substances” or sometimes “green primaries” usually covers substances used as primary explosives as well as substances used in priming mixtures. This may be even more confusing and we will therefore try to distinguish only between “green primary explosives” and “green priming mixtures” with the first ones being the replacement for LA in blasting caps and detonators while the second is a replacement for LS in priming compositions.

Historically the oldest toxic initiating substance is MF. It has to all intents and purposes been replaced in both igniting and detonating initiating devices by lead alternatives. Today these lead-based alternatives coexist with the more modern lead-less compounds or compositions containing other, less toxic, heavy metals. The efforts in finding suitable priming compositions were more successful and led to mixtures not containing lead such as SINTOX, NONTOX, WINCLEAN [5], CCI Clean Fire [6], etc. [7–9]. Future research is therefore aimed toward completely nontoxic alternatives. Results from the search for lead-free primary explosives were not particularly good, and a suitable replacement of lead azide practically does not exist today. The emergence in recent years of a new class of transition metal complexes is a direct response to the toxicity of heavy metals and environmental concerns. From recently published works, one of the more promising possibilities is found in complexes with high nitrogen content such as tetrazoles with nontoxic cations such as sodium, ammonium, and iron [10]. The evolution of the initiating substances and compositions with respect to toxicity is schematically summarized in Fig. 1.4.

In Fig. 1.4 “toxic” refers to the classical compositions with toxic heavy metals, “less toxic” substances relate to those not containing toxic heavy metals but still containing some problematic ingredients, and “green” to nontoxic substances.

The search for suitable replacements of LA and LS should not be seen as a search for one universal substance. It would obviously be nice to have one substance

Table 1.3 Target properties of green explosives and priming mixtures

Criteria	Green primary explosive (blasting caps, detonators)	Green priming mixture (electric pills, percussion caps)
Chemically stable under light, moisture, and in presence of carbon dioxide	X	X
Sufficient thermal stability	X	X
Low toxicity (no heavy metals, DDNP, ClO ₄ ⁻)	X	X
Sensitivity within useful limits	X	X
High initiation efficiency	X	
Resistant to dead-pressing good compatibility with construction materials	X	
Fast DDT	X	Unwanted
High flame temperature		X
Low barrel erosion/corrosion		X
Low antilubricating effect		X
Low cost	X	X

replacing both lead salts in both applications but with respect to their different function it should not be the ultimate goal due to different requirements for suitable replacements. High initiation efficiency, very important in primary explosives, is not at all important in primers and suitable properties with respect to barrel corrosion, very important in primers, are practically meaningless in detonators.

Six criteria for “green primaries” have been proposed including [10]:

1. Lack of sensitivity to light and moisture.
2. Sensitivity to initiation in suitable limits (sensitive enough to be initiated by nonexplosive stimulus but not too sensitive to make handling and transport unnecessarily risky).
3. Thermally stable to at least 200 °C.
4. Chemically stable for an extended period.
5. Devoid of toxic metals such as lead, mercury, silver, barium, or antimony.
6. Free of perchlorate which may be a possible teratogen and have an adverse effect on thyroid function.

These criteria are in our opinion relatively broad and cover both primary explosives as well as priming mixtures but do not include some important properties specific to each group. We are therefore proposing criteria summarized in Table 1.3.

It should be also pointed out that the toxicity of combustion products of classical priming mixtures today is mainly concerned with air born lead. It must therefore be stressed that using a lead-free priming mixture would have a somewhat questionable effect if a lead bullet without at least an enclosed bottom were to be used. More

Table 1.4 Some compositions of priming compositions without heavy metals

Substance	Composition (%)					
	Reported by Kusak			FA956	SINTOX	NONTOX
DDNP	35.0	29.8	40.0	37.0 ± 5	Unreported amount	–
Tetrazene	8.0	19.8	20.0	4.0 ± 1	Unreported amount	Unreported amount
PETN	–	–	–	5.0 ± 1	–	Unreported amount
CuO	–	29.8	–	–	–	–
MnO ₂	–	–	10.0	–	–	–
Ba(NO ₃) ₂	38.0	–	–	32.0 ± 5	–	–
KNO ₃	–	–	–	–	–	Unreported amount
ZnO ₂	–	–	–	–	Unreported amount	–
Sb ₂ S ₃	12.0	–	–	15.0 ± 2	–	–
B	–	–	–	–	–	Unreported amount
Al	7.0	9.8	–	7.0 ± 1	–	–
Ti	–	–	–	–	Unreported amount	–
Glass	–	9.8	28.0	–	–	Unreported amount
Binder	–	1.0	2.0	0.2	Unreported amount	Unreported amount
References	[11]	[11]	[11]	[1]	[3]	[8]

suitable in this case are either fully encapsulated bullets or bullets made from metals other than lead.

Various new energetic materials have been designed and tested as potential candidates for replacement of the lead substances. The green priming mixtures for percussion caps of small arms ammunition for indoor shooting usually use DDNP or tetrazene (or both) as a replacement for trinitrate. DDNP, although better than lead salts, is reported to cause some allergic reactions [10]. Example compositions without heavy metals are summarized in Table 1.4.

A suitable replacement for lead azide in detonators still does not exist even though new candidates, mostly based on tetrazole complexes, have been proposed and to a certain limited extent even employed. There are also some alternative approaches which eliminate toxic metals from the detonator by eliminating the primary explosive but they have not yet succeeded in replacing lead azide detonators.

Environmental friendliness is of course only one important aspect to be considered. Explosives that show extraordinary properties such as stability, sensitivity, initiation efficiency, compatibility, or other properties can find their application in some special cases even though they will not meet the green criteria. Typical examples of such explosives may be the mercury salt of tetrazole or cirkon (cadmium(II)tris-carbonohydrazide) perchlorate used in Russia [12, 13].

An enormous amount of work has been done in Russia on perchlorate coordination complexes. A very interesting initiative to find “green” primary explosives among the cobalt perchlorate complexes has been reported by Ilyushin et al. [14]. The differences in perception of toxicity in various parts of the world make direct comparison misleading. Perchlorates, which are not seen as a problem in many countries, are considered unsuitable from the long-term perspective in the USA [10].

References

1. Fedoroff, B.T., Sheffield, O.E., Kaye, S.M.: Encyclopedia of Explosives and Related Items. Picatinny Arsenal, Dover, NJ (1960–1983)
2. Krauz, C.: Technologie výbušin. Vědecko-technické nakladatelství, Praha (1950)
3. Hagel, R., Redecker, K.: Sintox – a new, non-toxic primer composition by Dynamit Nobel AG. *Propell. Explos. Pyrotech* **11**, 184–187 (1986)
4. Burns, J.E.: Priming mixture. US Patent 1,880,235, 1932
5. Mei, G.C., Pickett, J.W.: Lead-free priming mixture for percussion primer. US Patent 5,417,160, 1995
6. Bjerke, R.K., Ward, J.P., Ells, D.O., Kees, K.P.: Primer composition. US Patent 4,963,201, 1990
7. Brede, U., Hagel, R., Redecker, K.H., Weuter, W.: Primer compositions in the course of time: from black powder and SINOXID to SINTOX compositions and SINCO booster. *Propell. Explos. Pyrotech* **21**, 113–117 (1996)
8. Nesveda, J., Brandejs, S., Jirásek, K.: Non toxic and non-corrosive ignition mixtures. Patent WO 01/21558, 2001
9. Oommen, Z., Pierce, S.M.: Lead-free primer residues: a qualitative characterization of Winchester WinClean, Remington/UMC LeadLess, Federal BallistiClean, and Speer Lawman CleanFire handgun ammunition. *J. Forensic Sci.* **51**, 509 (2006)
10. Huynh, M.V., Coburn, M.D., Meyer, T.J., Wetzler, M.: Green primaries: environmentally friendly energetic complexes. *Proc. Natl. Acad. Sci. USA* **103**, 5409–5412 (2006)
11. Kusák, J., Klecka, J., Lehký, L., Svachouček, V., Pechouček, P.: Základy konstrukce munice. Ediční středisko University Pardubice, Pardubice (2003)
12. Danilov, J.N., Ilyushin, M.A., Tselinskii, I.V.: Promyshlennye vzryvchatye veshchestva; chast I Iniciiiruyushchie vzryvshchatye veshchestva. Sankt-Peterburgskii gosudarstvennyi tekhnologicheskii institut, Sankt-Peterburg (2001)
13. Andreev, V.V., Neklyudov, A.G., Pozdnyakov, S.A., Fogelzang, A.E., Sinditskii, V.P., Serushkin, V.V., Egorshchikov, V.Y., Kolesov, B.I.: Kapsyul-detonator (varianty). Patent RU 2,104,466, 1996
14. Ilyushin, M.A., Tselinskii, I.V., Sudarikov, A.M.: Razrabotka komponentov vysokoenergeticheskikh kompozitsii. SPB:LGU im. A. S. Pushkina - SPBGTI(TU), Sankt-Peterburg (2006)